

'Feel
your Airport'

Primary Cable is the Backbone

GE-STB

Elevated Stop Bar Light

ICAO

Aerodrome Design Manual
Annex 14, Volume 1

EASA

CS-ADR-DNS Issue 5

AENA

DIN/DSEYN/PPT/018-03/12

STAC

SPE/SE/E/VIS/6008

IEC

61827

FAA

AC150/5345-46, EB67

Elevated Stop Bar Light

Description

Low consumption dimmable LED light (EB67).

Compatible with existing AGL infrastructures (6.6A IEC/FAA CCRs, thyristor or IGBT).

Transformerless architecture with low inrush current and high power factor.

Cast aluminium body -UV-resistant powder coating.

Shared parts across the whole range of lights thanks to a modular design, to reduce spare references.

Open fail monitoring capability.

Surge protection.

Technical Data

Enviroment	
Operating temperature	-55°C/+55°C
Storage temperature	-55°C/+85°C
Protection index	IP68
Humidity	0%-100%
Mechanical	
Width	152mm
Height	249,50mm
Weight	2,9kg
Electrical	
Power Supply	2,8A - 6,6A
Max admissible current	12A
Power Consumption	<6,5W (<15W high intensity)
Power factor	>97%
Life span	>80000H

Drawing

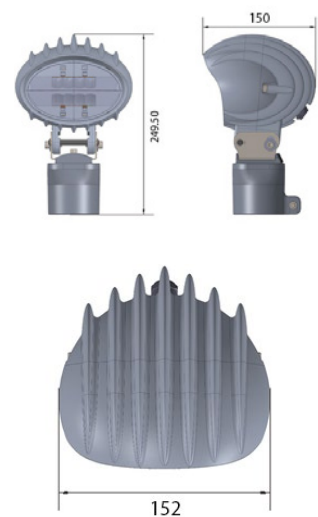

Chromaticity

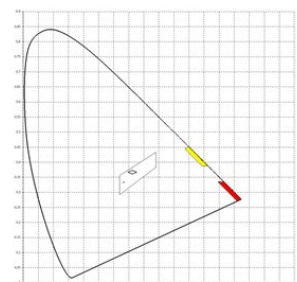

Photometry

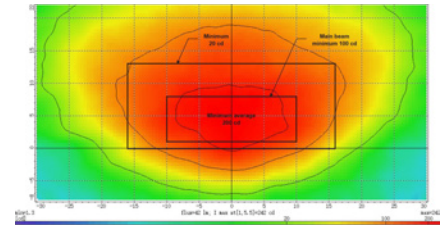

Red

Components and spare parts

Drawing Reference	Part	Code
1 and 2	Elevated unidi. light front part, lens assembled	ELEVBOD0003
5, 6 and 7	Elevated unidi. light back part	ELEVBOD0004
-	Elevated unidi. adjustment mechanism	ELEVBOD0005
2	Elliptical seal ring for elevated unidir. light	ELEVBOD0006
-	LED connection cable Ø2	ELEVINT0000
6	Light cable lead 50cm long	LIAC0000001
-	Electronic FOM module (5503)	LIACINT0000
4	Driver module	LIACINT0007
3	LED light source R050A	ELEVLEDRS00
-	Breakable coupling	LIACINSEL01
-	Baseplate 187mm	LIACINSEL00

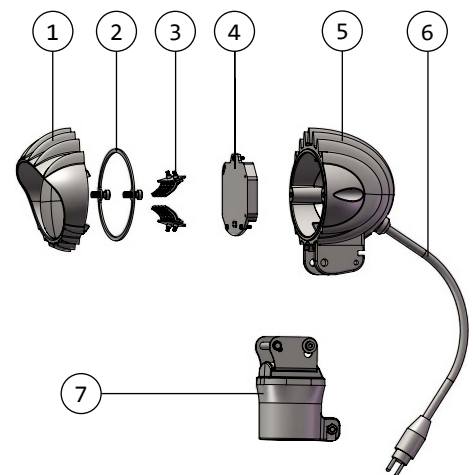

Ordering Code

COLOUR

R (Red), HR (High Intensity Red)

MONITORING

0 No
1 Fail open

GE-STB - R - X

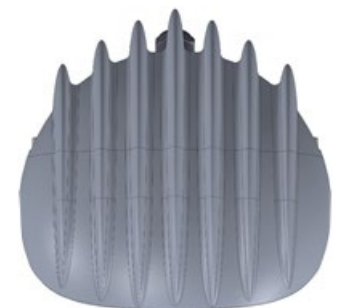



GRP Iluminación, S.A.U.

Calle de los Reyes Católicos, 6. Nave 102
28108 - Alcobendas (Madrid) - Spain / +34 91 327 19 66



GRP

www.grp-airsys.com