

'Feel
your Airport'

Primary Cable is the Backbone

GI-ACL

*Inset Approach Centreline and
Cross Bar Light*

Standard compliance

ICAO

Aerodrome Design Manual
Annex 14, Volume 1

EASA

CS-ADR-DNS Issue 5

AENA

DIN/DSEYN/PPT/010-03/12

STAC

SPE/SE/E/VIS/6008

IEC

61827

FAA

AC150/5345-46, EB67

Use

Inset Approach Centreline and
Cross Bar Light

Description

Low protrusion (6mm) 12" inset light.

Low consumption dimmable LED light (EB67).

Compatible with existing AGL infrastructures (6.6A IEC/FAA CCRs, thyristor or IGBT).

Transformerless architecture with low inrush current and high power factor.

Forged aluminium body.

Shared parts across the whole range of lights thanks to a modular design, to reduce spare references.

Open fail monitoring capability.

Surge protection.

Technical Data

Environment	
Operating temperature	-55°C/+55°C
Storage temperature	-55°C/+85°C
Protection index	IP68
Humidity	0%-100%
Mechanical	
Diameter	304mm
Protrusion	6mm
Height	89mm
Weight	6kg
Electrical	
Power Supply	2,8A - 6,6A
Max admissible current	12A
Power Consumption	<54W
Power factor	>97%
Life span	>80000H

Drawing

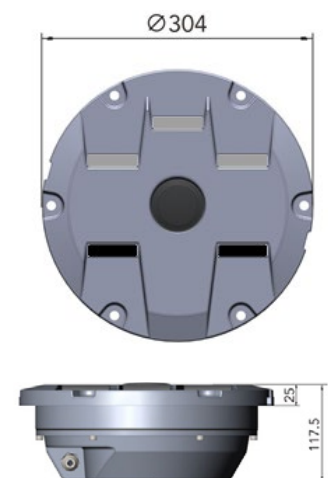

Chromaticity

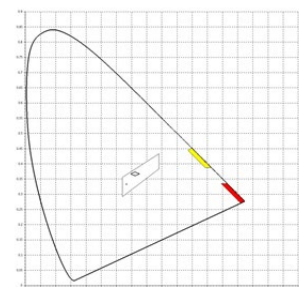

Photometry

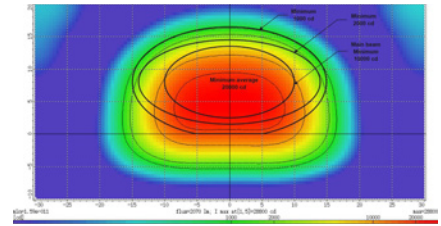

White

Components and spare parts

Drawing Reference	Part	Code
1, 2 and 4	12" inset unidi. top part, 3 prisms assembled	IN12TOP0000
6 and 7	12" inset bottom part, single	IN12BOT0000
4	Prism support for 12" inset	IN12INT0000
-	LED connection cable 03	IN12INT0001
-	Label for white straight	LIACINTWS00
-	Electronic FOM module (5503)	LIACINT0000
2	Seal ring for 12" inset light fixture	IN12INT0002
-	Seal ring for 12" base	IN12EXT0001
5	Driver module for 1 cable lead	LIACINT0004
3	LED light source W1A0D	IN12LEDW000
7	Light cable lead 40cm long with gland	LIAC0000000

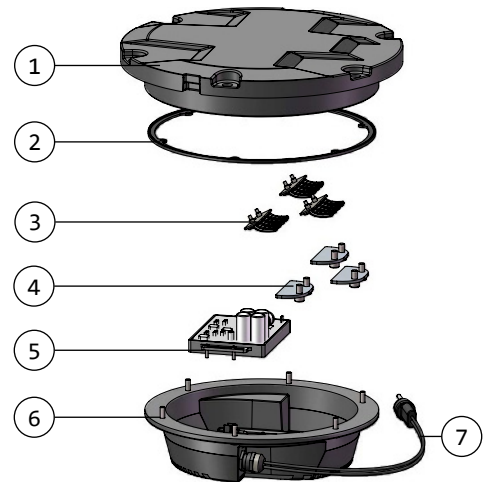

Ordering Code

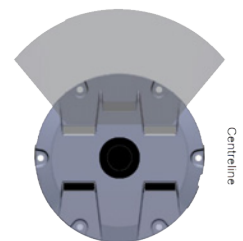
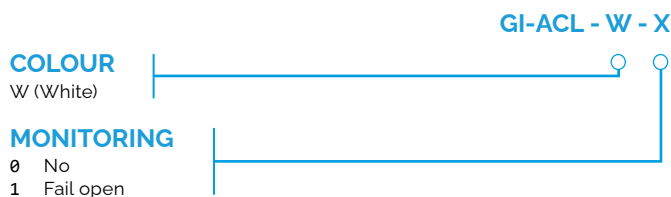



GRP Iluminación, S.A.U.

Calle de los Reyes Católicos, 6. Nave 102
28108 - Alcobendas (Madrid) - Spain / +34 91 327 19 66



GRP

www.grp-airsys.com