

*'Feel  
your Airport'*

*Primary Cable is the Backbone*

# *GI-TED*

*Inset Taxiway Edge Light*

## Standard compliance

### ICAO

Aerodrome Design Manual  
Annex 14, Volume 1

### EASA

CS-ADR-DNS Issue 5

### AENA

DIN/DSEYN/PPT/017-06/12

### STAC

SPE/SE/E/VIS/6008

### IEC

61827

### FAA

AC150/5345-46, EB67

## Use

Inset Taxiway  
Edge Light

## Description

Low protrusion (3,5mm) 8" inset light.

Low consumption dimmable LED light (EB67).

Compatible with existing AGL infrastructures (6,6A IEC/FAA CCRs, thyristor or IGBT).

Transformerless architecture with low inrush current and high power factor.

Forged aluminium body.

Shared parts across the whole range of lights thanks to a modular design, to reduce spare references.

Open fail monitoring capability.

Surge protection.

## Technical Data

Enviroment	
Operating temperature	-55°C/+55°C
Storage temperature	-55°C/+85°C
Protection index	IP68
Humidity	0%-100%
Mechanical	
Diameter	203mm
Protrusion	3,5mm
Height	89mm
Weight	2,8kg
Electrical	
Power Supply	2,8A - 6,6A
Max admissible current	12A
Power Consumption	<6W
Power factor	>97%
Life span	>80000H

## Drawing

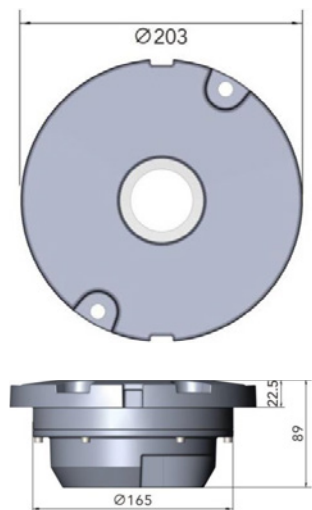

## Chromaticity

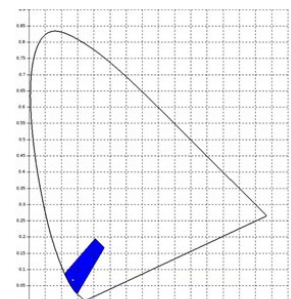

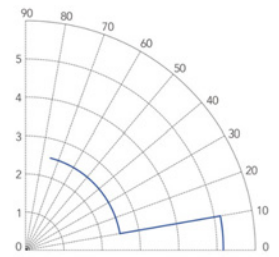

Blue

## Components and spare parts

Drawing Reference	Part	Code
1 and 2	8" inset unidi. top part, prism assembled	IN08TOP0002
6 and 7	8" inset bottom part, single	IN08BOT0000
-	LED connection cable 01	IN08INT0000
2	Seal ring for 8" inset light fixture	IN08INT0002
-	Seal ring for 8" base type T	LIACEXT0000
-	Electronic FOM module (5503)	LIACINT0000
5	Driver module for 1 cable lead	LIACINT0002
3	LED light source B2R0H	IN08LEDB000
7	Light cable lead 40cm long with gland	LIAC0000000

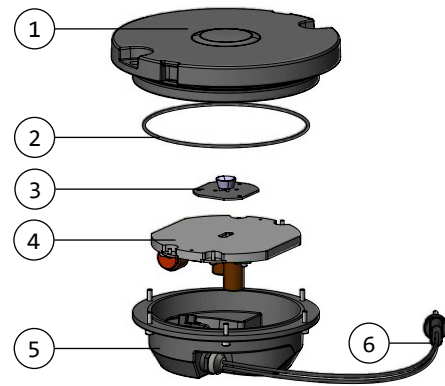

## Ordering Code





**GRP Iluminación, S.A.U.**

Calle de los Reyes Católicos, 6. Nave 102  
28108 - Alcobendas (Madrid) - Spain / +34 91 327 19 66



**GRP**

[www.grp-airsys.com](http://www.grp-airsys.com)